

ANCHOR PLATE ALTERNATE A-1

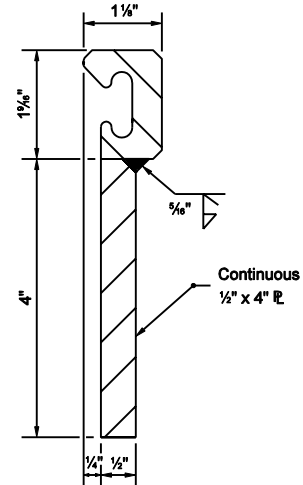

**EXTRUSION & PLATE
ASSEMBLY DETAIL**

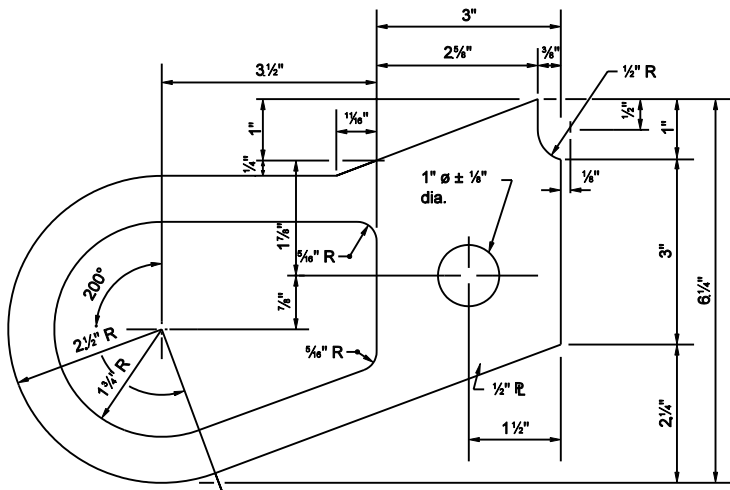

ANCHOR PLATE ALTERNATE A-2

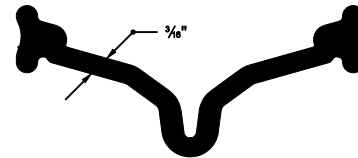

STRIP SEAL

INDIANA DEPARTMENT OF TRANSPORTATION

EXPANSION JOINTS
CLASS SS (ALTERNATE A)

SEPTEMBER 2003

STANDARD DRAWING NO. E 724-BSSJ -01

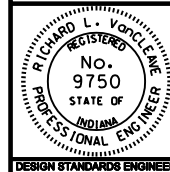

/s/ Richard L. VanCleave 9-02-03
DESIGN STANDARDS ENGINEER DATE

/s/ Richard K. Smutzer 9-02-03
CHIEF HIGHWAY ENGINEER DATE

DESIGN STANDARDS ENGINEER

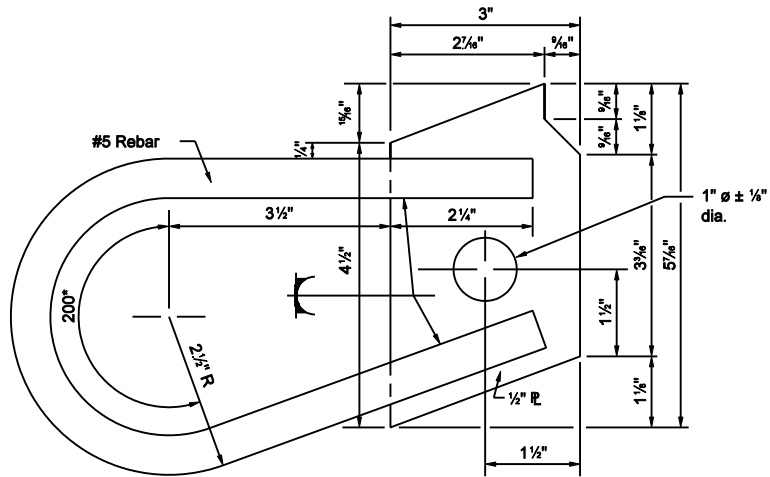

ANCHOR PLATE ALTERNATE B-1

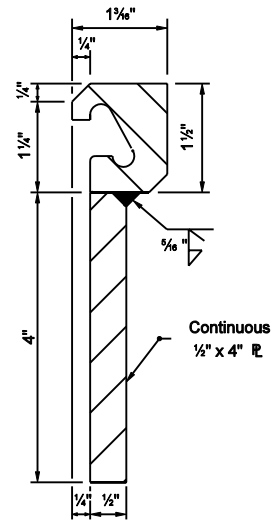

**EXTRUSION & PLATE
ASSEMBLY DETAIL**

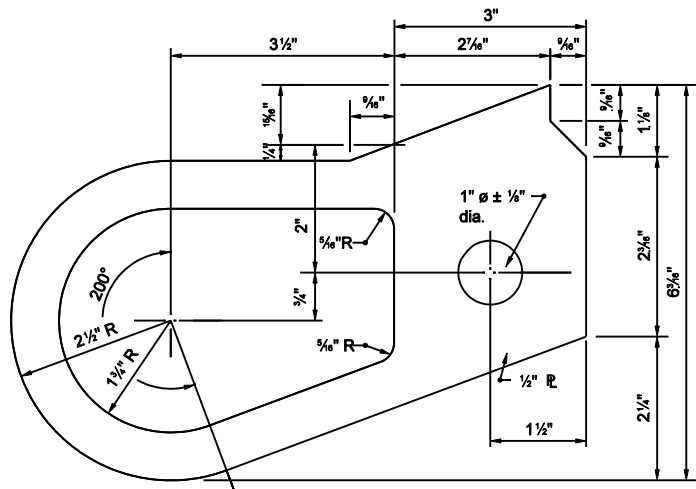

ANCHOR PLATE ALTERNATE B-2

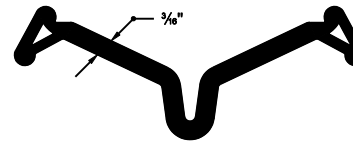

STRIP SEAL

INDIANA DEPARTMENT OF TRANSPORTATION	
EXPANSION JOINTS CLASS SS (ALTERNATE B)	
SEPTEMBER 2003	
STANDARD DRAWING NO. E 724-BSSJ -02	
	/s/ Richard L. VanCleave 9-02-03 DESIGN STANDARDS ENGINEER DATE
	/s/ Richard K. Smutzer 9-02-03 CHIEF HIGHWAY ENGINEER DATE
DESIGN STANDARDS ENGINEER	

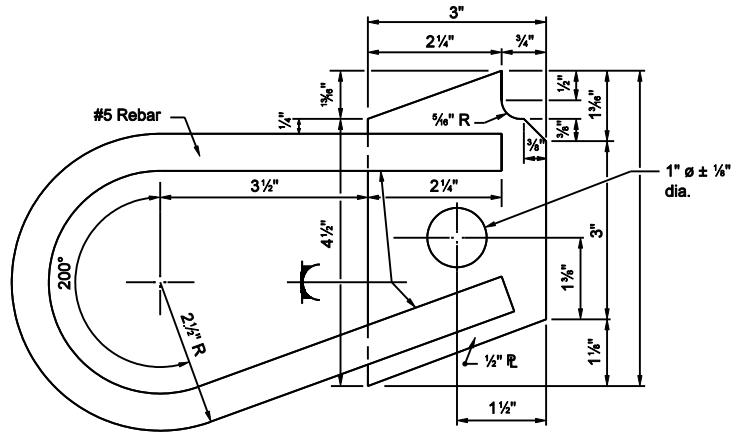

ANCHOR PLATE ALTERNATE C-1

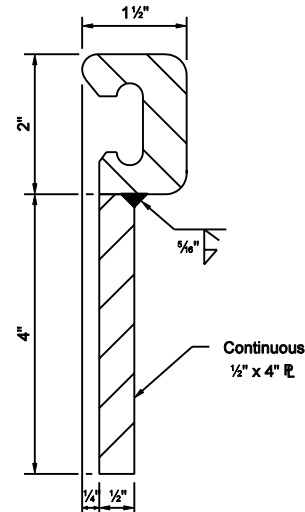

**EXTRUSION & PLATE
ASSEMBLY DETAIL**

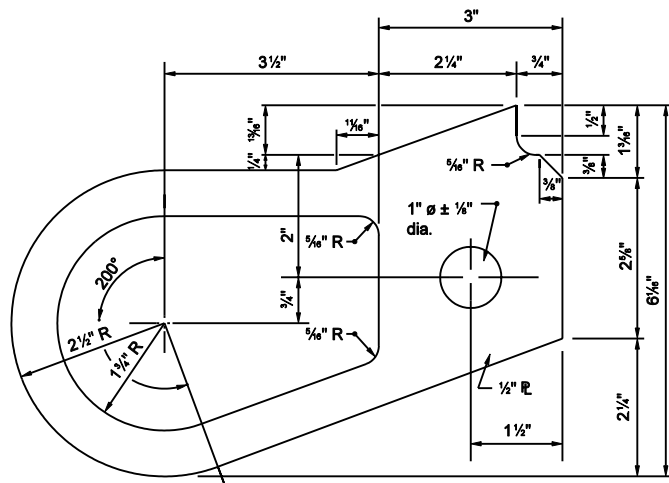

ANCHOR PLATE ALTERNATE C-2

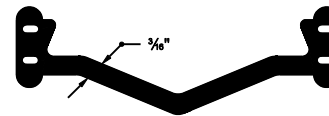

STRIP SEAL

INDIANA DEPARTMENT OF TRANSPORTATION	
EXPANSION JOINTS CLASS SS (ALTERNATE C)	
SEPTEMBER 2003	
STANDARD DRAWING NO. E 724-BSSJ-03	
	/s/ Richard L. VanCleave 9-02-03 DESIGN STANDARDS ENGINEER DATE
	/s/ Richard K. Smutzer 9-02-03 CHIEF HIGHWAY ENGINEER DATE

GENERAL NOTES

1. This sheet shall be used in conjunction with Standard Drawing Nos. E 724-BSSJ-05 through 09.
2. Allowable expansion lengths shall not be increased for skewed structures.
- ③ Tool concrete edges to 1/4" to 3/8" radius.
- ④ Anchors shall be spaced at 9 in.

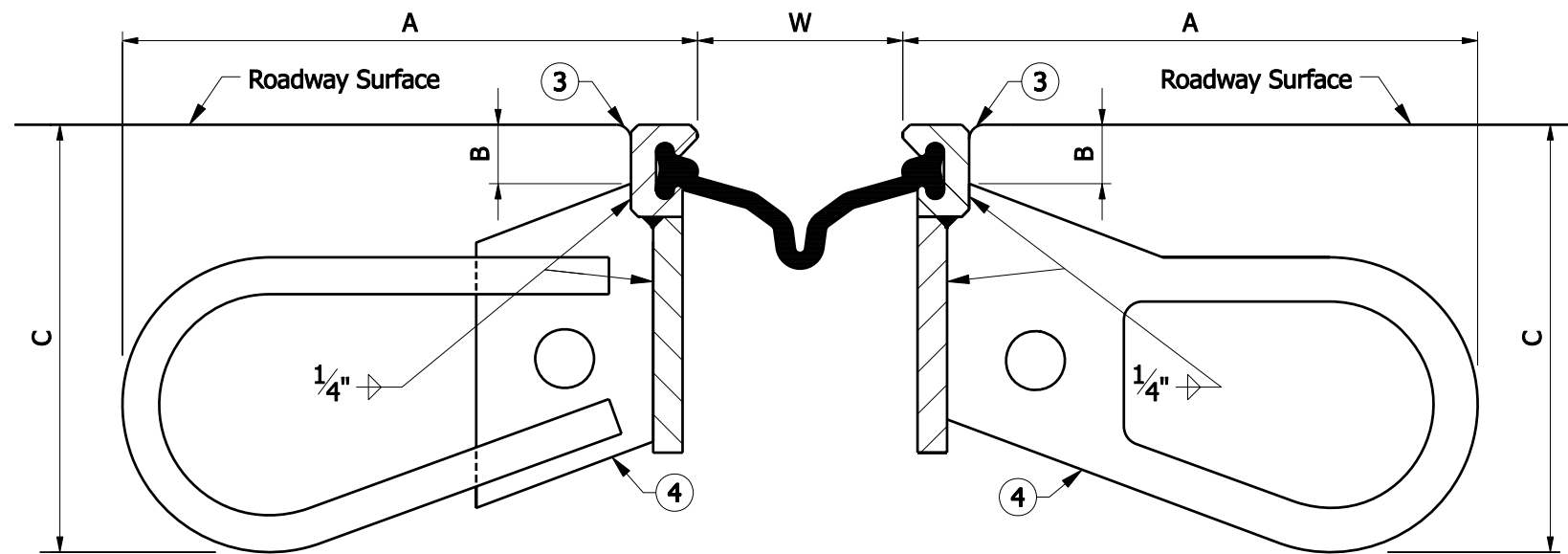

INSTALLATION DETAIL

DIMENSIONS

ALTERNATES	A	B	C
A-1	9 3/4"	1"	7 1/4"
A-2			
B-1	9 3/4"	15 1/16"	7 1/8"
B-2			
C-1	9 3/4"	1 13/16"	7 1/4"
C-2			
D-1	9 3/4"	1"	7 5/16"
D-2			

JOINT SETTING TABLE

Ambient Temperature °F	DIMENSION "W"		
	Expansion Length		
	100'-200'	200'-300'	300'-400'
120°	2 1/8"	1 5/16"	1/2"
100°	2 7/16"	1 3/4"	1 1/8"
80°	2 11/16"	2 3/16"	1 11/16"
60°	3"	2 5/8"	2 1/4"
40°	3 5/16"	3 1/16"	2 13/16"
20°	3 9/16"	3 1/2"	3 3/8"
0°	3 7/8"	3 5/16"	4"

INDIANA DEPARTMENT OF TRANSPORTATION

**EXPANSION JOINTS
CLASS SS**

SEPTEMBER 2007

STANDARD DRAWING NO. E 724-BSSJ-04

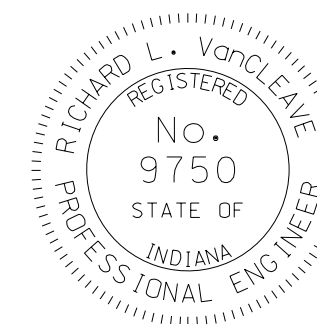

DESIGN STANDARDS ENGINEER

/s/ Richard L. VanCleave 09/04/07
DESIGN STANDARDS ENGINEER DATE

/s/ Mark A. Miller 09/04/07
CHIEF HIGHWAY ENGINEER DATE

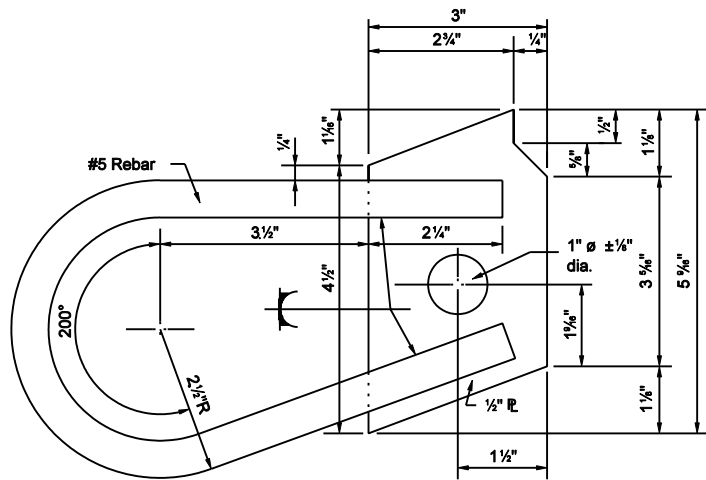

ANCHOR PLATE ALTERNATE D-1

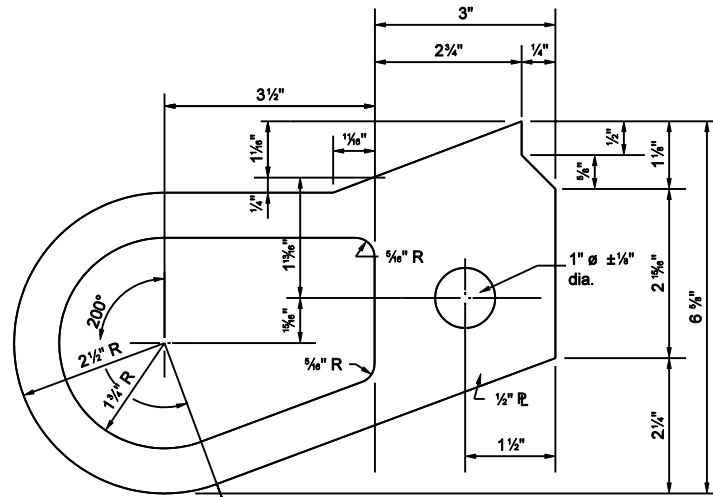

ANCHOR PLATE ALTERNATE D-2

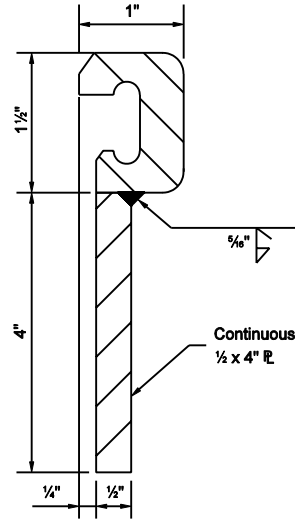

**EXTRUSION & PLATE
ASSEMBLY DETAIL**

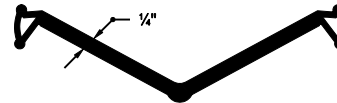

**RJ-400 STRIP
SEAL GLAND**

INDIANA DEPARTMENT OF TRANSPORTATION	
EXPANSION JOINTS CLASS SS (ALTERNATE D)	
SEPTEMBER 2003	
STANDARD DRAWING NO. E 724-BSSJ-04A	
	/s/ Richard L. VanCleave 9-02-03 DESIGN STANDARDS ENGINEER DATE
	/s/ Richard K. Smutzer 9-02-03 CHIEF HIGHWAY ENGINEER DATE

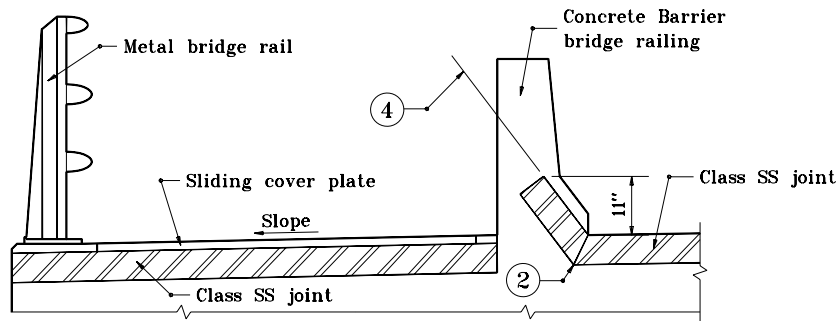

SECTION D-D

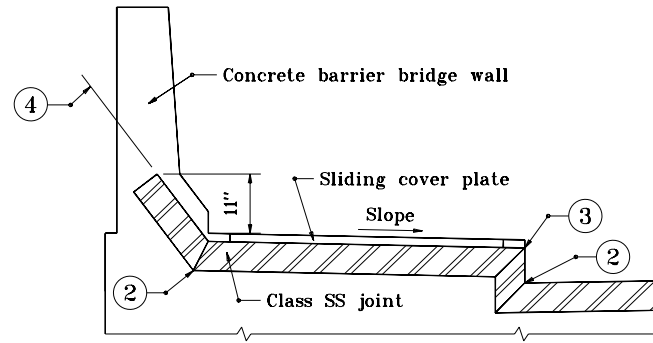

SECTION B-B

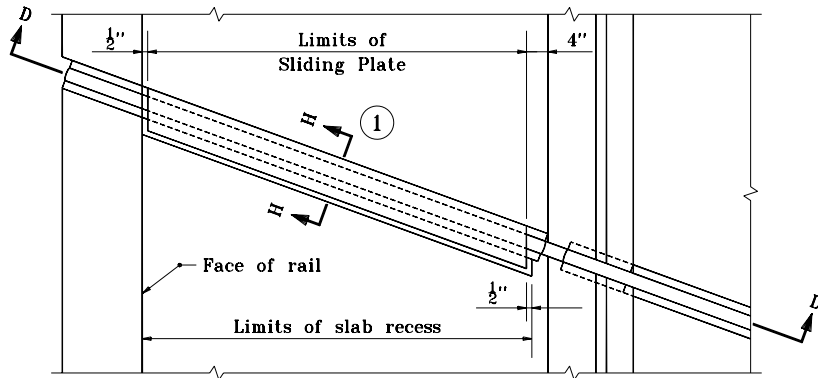

PLAN

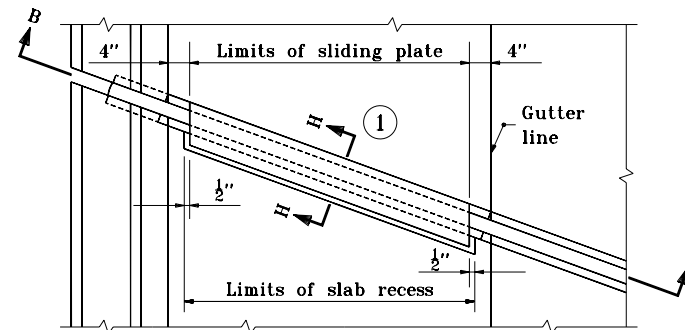

PLAN

SIDEWALKS

- ① For section H-H see sheet number E 724-BSSJ-08.
- ② The extrusion and plate assemblies with anchors shall be miter cut and shop spliced at this location. A miter cut, vulcanized shop splice will be require in the strip seal at this location.
- ③ The extrusion and plate assemblies with anchors shall be shop prepared for field welding at this location. A miter cut vulcanized shop splice will be require in the strip seal at this location.
- ④ The joint shall be placed parallel to the lower sloped face of the rail with a maximum 3 in. depth to the top of the extrusion.

INDIANA DEPARTMENT OF TRANSPORTATION

EXPANSION JOINTS CLASS SS

SEPTEMBER 1994

STANDARD DRAWING NO. E 724-BSSJ-05

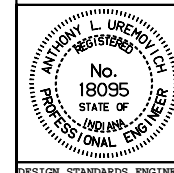

DETAILS PLACED IN THIS FORMAT 11-15-99

/s/ Anthony L. Uremovich 11-15-99
DESIGN STANDARDS ENGINEER DATE

/s/ Firooz Zandi 11-15-99
CHIEF HIGHWAY ENGINEER DATE

DESIGN STANDARDS ENGINEER

ORIGINALLY APPROVED 9-30-94

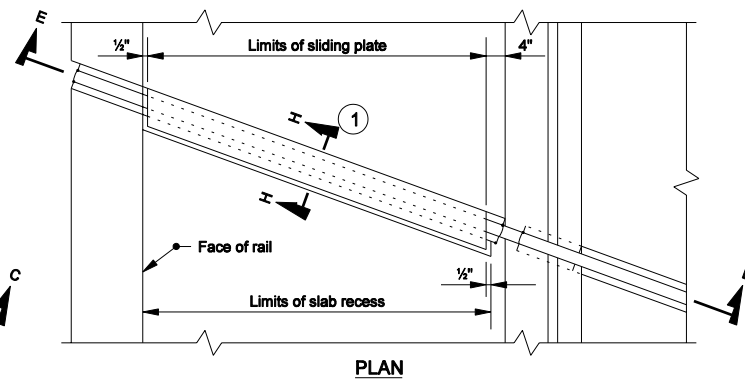
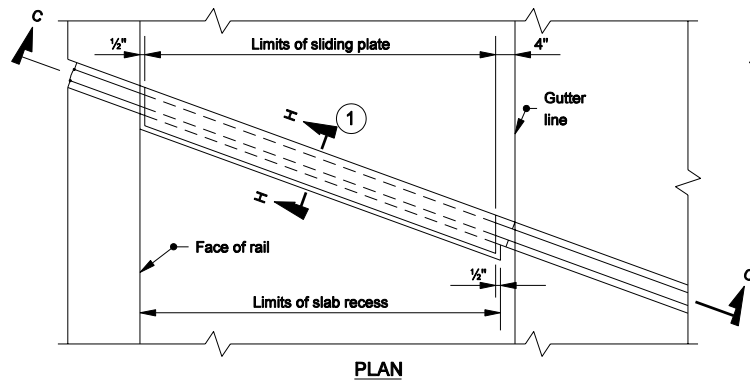
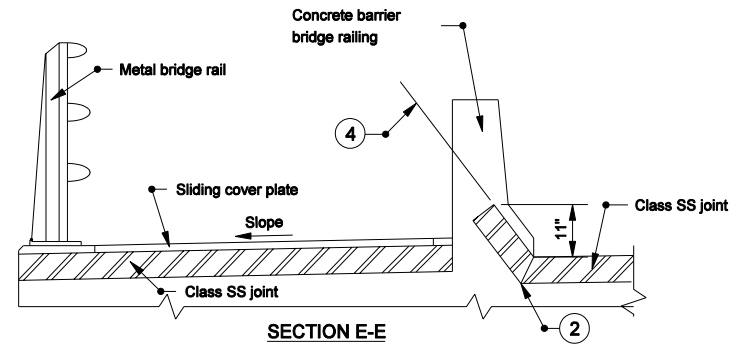
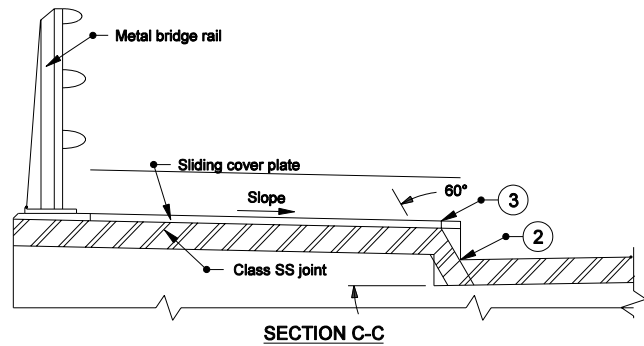

SIDEWALKS

- ① For section H-H see sheet number E 724-BSSJ-08.
- ② The extrusion and plate assemblies with anchors shall be miter cut and shop spliced at this location. A miter cut, vulcanized shop splice will be required in the strip seal at this location.
- ③ The extrusion and plate assemblies with anchors shall be shop prepared for field welding at this location. A miter cut vulcanized shop splice will be required in the strip seal at this location.
- ④ The joint shall be placed parallel to the lower sloped face of the rail with a maximum 3 in. depth to the top of the extrusion.

INDIANA DEPARTMENT OF TRANSPORTATION

**EXPANSION JOINTS
CLASS SS
MARCH 2005**

STANDARD DRAWING NO. E 724-BSSJ-06

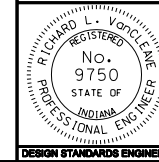

/s/ Richard L. VanCleave 3-01-05
DESIGN STANDARDS ENGINEER DATE

/s/ Richard K. Smutzer 3-01-05
CHIEF HIGHWAY ENGINEER DATE

DESIGN STANDARDS ENGINEER

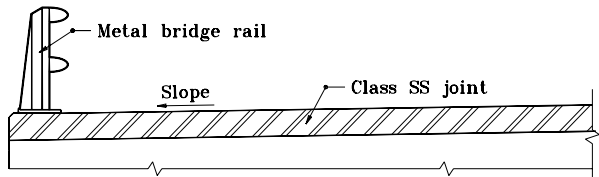

SECTION F-F

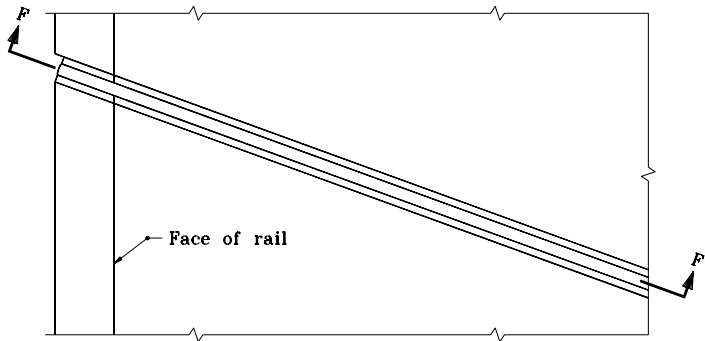

PLAN

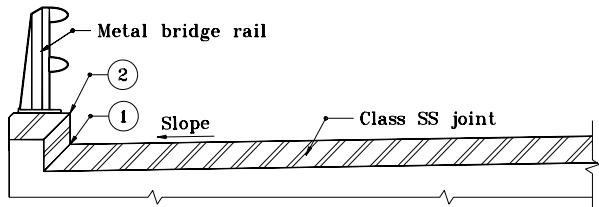

SECTION G-G

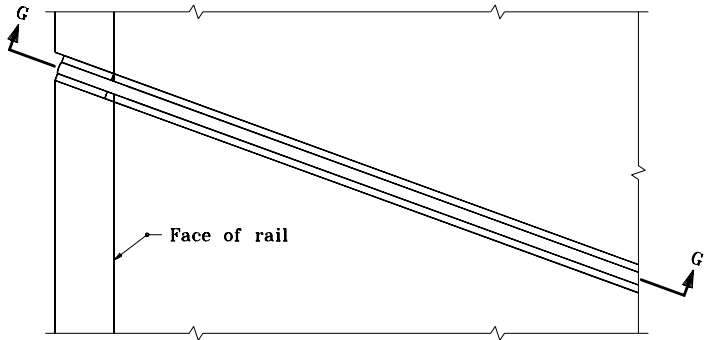

PLAN

METAL RAILING WITHOUT SIDEWALK

- ① The extrusion and plate assemblies with anchors shall be miter cut and shop spliced at this location. A miter cut, vulcanized shop spliced will be required in the strip seal at the location.
- ② The extrusion and plate assemblies with anchors shall be shop prepared for field welding at this location. A miter cut, vulcanized shop splice will be required in the strip seal at this location.

INDIANA DEPARTMENT OF TRANSPORTATION

EXPANSION JOINTS CLASS SS

SEPTEMBER 1994

STANDARD DRAWING NO. **E 724-BSSJ-07**

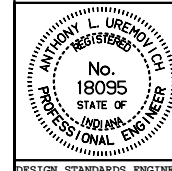

DETAILS PLACED IN THIS FORMAT 11-15-99

/s/ *Anthony L. Uremovich* 11-15-99
DESIGN STANDARDS ENGINEER DATE

/s/ *Firooz Zandi* 11-15-99
CHIEF HIGHWAY ENGINEER DATE

DESIGN STANDARDS ENGINEER

ORIGINALLY APPROVED

9-30-94

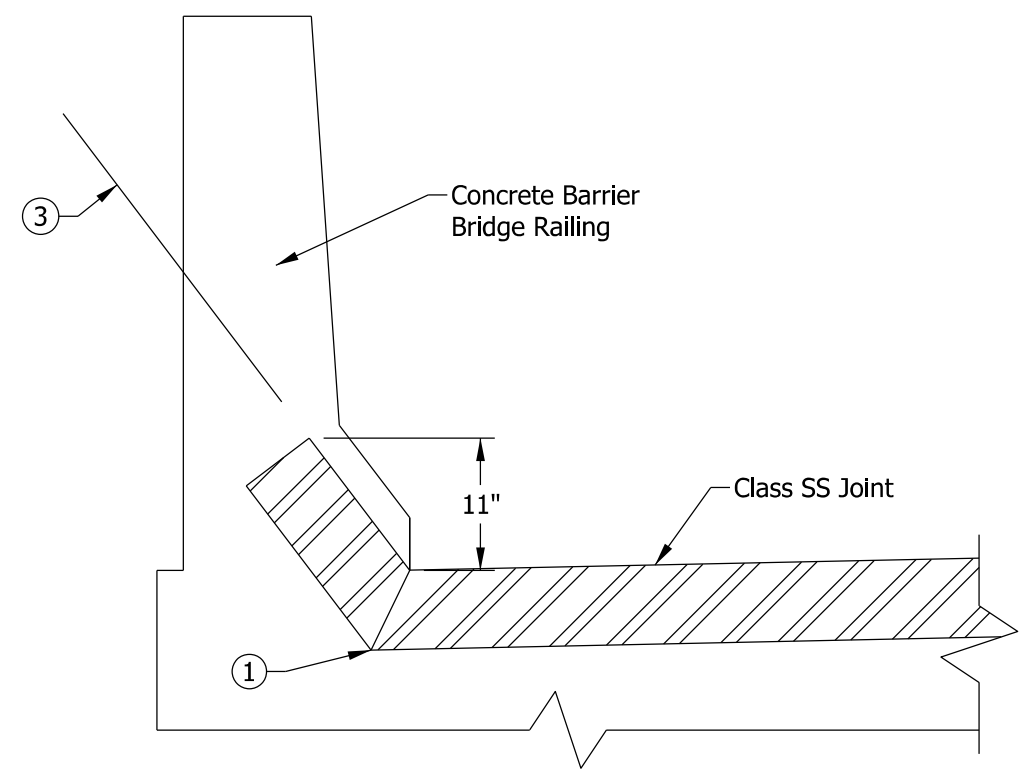
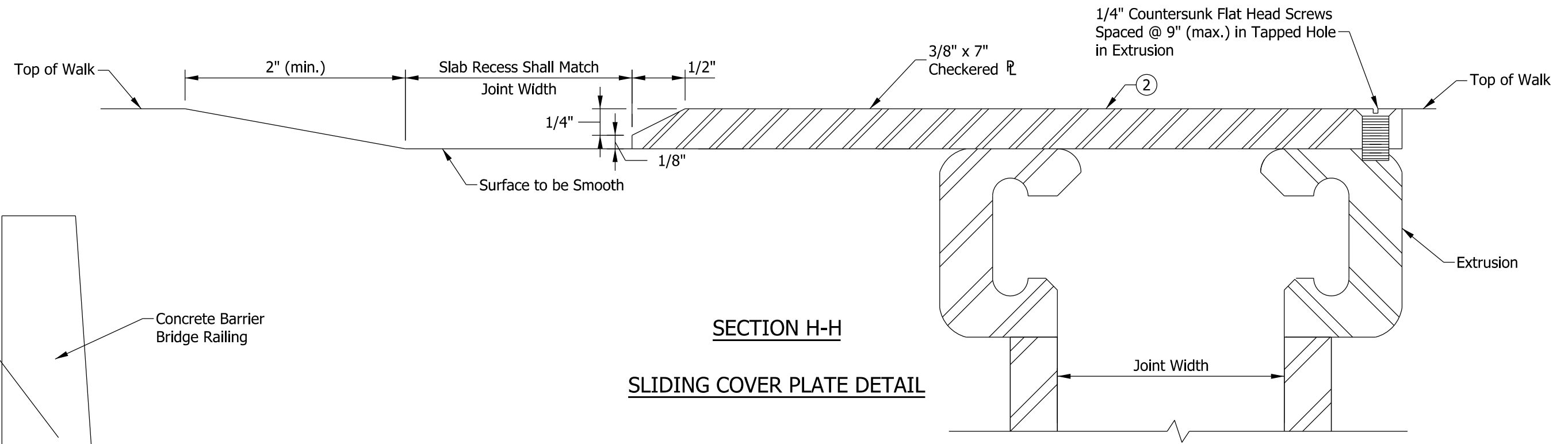

SECTION H-H
SLIDING COVER PLATE DETAIL

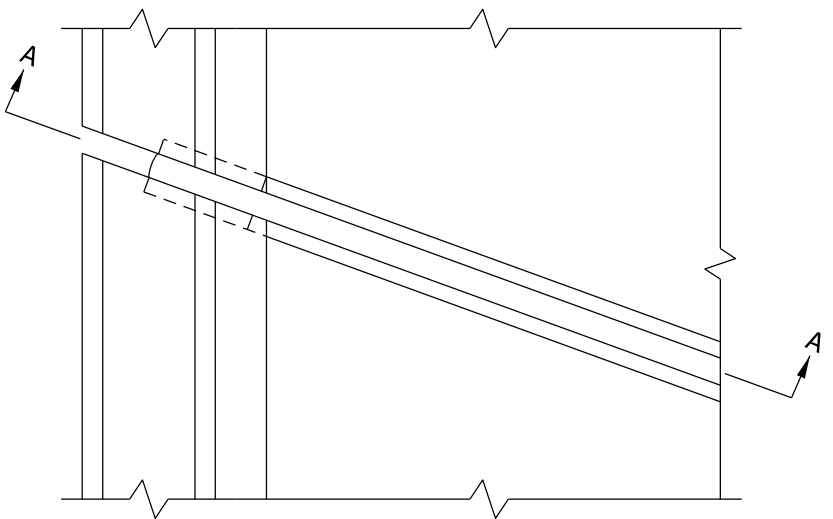

CONCRETE BARRIER BRIDGE RAILING

NOTES:

- ① The extrusion and plate assemblies with anchors shall be miter cut and shop spliced at this location. A miter cut, vulcanized shop splice will be required in the strip seal at this location.
- ② The length of the sliding cover plate, measured along the centerline of the Class SS Joint, shall be 3/8" shorter at each end than the limits of the recess as shown on these details.
- ③ The joint shall be placed parallel to the lower sloped face of the rail with a maximum 3" depth to the top of the extrusion.

SECTION A-A

INDIANA DEPARTMENT OF TRANSPORTATION	
EXPANSION JOINTS CLASS SS	
SEPTEMBER 2021	
STANDARD DRAWING NO.	E 724-BSSJ-08
	<p style="text-align: right;"><i>Jeremy C. Hunter</i> 3/2/2021 DESIGN STANDARDS ENGINEER DATE</p> <p style="text-align: right;"><i>[Signature]</i> 03/17/2021 CHIEF ENGINEER DATE</p>

GENERAL NOTES

1. Standard Drawing Nos. E 724-BSSJ-05 through 09 shall be used in conjunction with Standard Drawing Nos. E 724-BSSJ-01 through 04.
2. The details shown on Standard Drawing Nos. E 724-BSSJ-05 through 09 are the only approved methods of placing Class SS Joints in curbs, sidewalks, concrete bridge railing and under metal bridge railing.
3. The locations of the anchor plates in sidewalks and in the concrete barrier bridge rail shall be as shown on the approved shop drawings but in no case shall the spacing exceed 9 in.

INDIANA DEPARTMENT OF TRANSPORTATION

EXPANSION JOINTS CLASS SS

SEPTEMBER 1994

STANDARD DRAWING NO. E 724-BSSJ-09

	DETAILS PLACED IN THIS FORMAT	11-15-99
	/s/ <i>Anthony L. Uremovich</i>	<i>11-15-99</i>
	DESIGN STANDARDS ENGINEER	DATE
	/s/ <i>Firooz Zandi</i>	<i>11-15-99</i>
	CHIEF HIGHWAY ENGINEER	DATE
DESIGN STANDARDS ENGINEER	ORIGINALLY APPROVED	9-30-94